

Model 100



The benefits of high-end light sensitivity, flexibility and image quality in a compact form factor

The highest specified model of the successful FASTCAM Mini product range of high speed cameras, the **FASTCAM Mini AX** delivers exceptional light sensitivity, image quality and flexible region of interest (ROI) to those customers that do not need the ultimate frame rate performance of the FASTCAM SA-X2 and SA-Z but would benefit from these same sensor features. The FASTCAM Mini AX100 delivers **1 Megapixel resolution** (1024x1024 pixels) at frame rates up to **4,000fps** with **4x (2 f-stops)** more light sensitivity than the FASTCAM Mini UX100. A practical **1µs** exposure duration independent of frame rate, the ability to record images at up to 540,000fps at reduced resolution and the compact hardware design, round off what we believe to be the perfect feature set for a mid-range camera system. With the increase in light sensitivity and housed within a 120mm x 120mm x 90mm, rugged camera body weighing just 1.5kg, the FASTCAM Mini AX is ideally suited for use in a wide range of scientific and industrial applications including combustion, micro-fluidics, PIV and DIC.

The camera is available with recording memory options up to 16GB providing extended recording times and triggering flexibility.

Standard operational features of the FASTCAM Mini AX range include a mechanical shutter to allow remote system calibration, Gigabit Ethernet interface for reliable system control and fast image transfer and the ability to remotely switch off cooling fans to eliminate vibration when recording at high magnifications - in particular applications such as digital image correlation (DIC) or microscopy and PIV.

fluid dynamics, combustion, PIV, material science, DIC, defence, aerospace, biomechanics, microscopy, microfluidics, life science

PRODUCT FEATURES:

1MP CMOS Sensor:

1024x1024 pixels @ 4,000fps

Frame Rate Performance Examples:

- 5,400fps at 1024x800 pixel resolution
- 10,800fps at 768x480 pixel resolution
- 13,600fps at 512x512 pixel resolution
- 37,500fps at 256x256 pixel resolution
- 61,200fps at 256x128 pixel resolution
- 102,000fps at 256x64 pixel resolution

Class Leading Light Sensitivity:

ISO 12232 Ssat (excluding IR response)

- ISO 40,000 monochrome
- ISO 16,000 color

Global Electronic Shutter

1ms to 1µs independent of frame rate

Dynamic Range (ADC):

12-bit Monochrome, 36-bit Colour

Compact and Lightweight :

120mm x 120mm x 90mm Camera Body
Weight: 1.5Kg

Internal Recording Memory

4GB, 8GB, 16GB

Fast Gigabit Ethernet Interface provides reliable system communication and fast image download.

Flexible Frame Synchronisation Frame rate may be synchronised to external non-stable frequencies.

Sensor Size and Integrated Nikon G Type Lens Mount allowing full compatibility with current DSLR lenses (DX and FX formats, G type Lens).

Fan Stop Function Remotely switch off cooling fans to eliminate vibration – particularly import when capturing events at high-magnification.

Image Sensor Technical Data:

Sensor Type	Proprietary Design Advanced CMOS
Maximum Resolution (pixels)	1024 x 1024 pixels
Sensor Size / Diagonal	20.48 x 20.48mm / 28.96mm
Pixel Size (microns)	20 μ m x 20 μ m
Quantum Efficiency	49% at 630nm
Full Well Capacity	16,000e-
Fill Factor	58%
Dark Noise	29e-
Sensor Dynamic Range	54.8 dB
Color Matrix	Bayer CFA (single sensor)
ISO 12232 Ssat sensitivity	ISO 40,000 mono, ISO 16,000 color (mono sensor equivalent > ISO64,000 T including near IR response)
Shutter	Global Electronic Shutter 1ms to 1 μ s independent of frame rate.

Image Sensor Spectral Response:

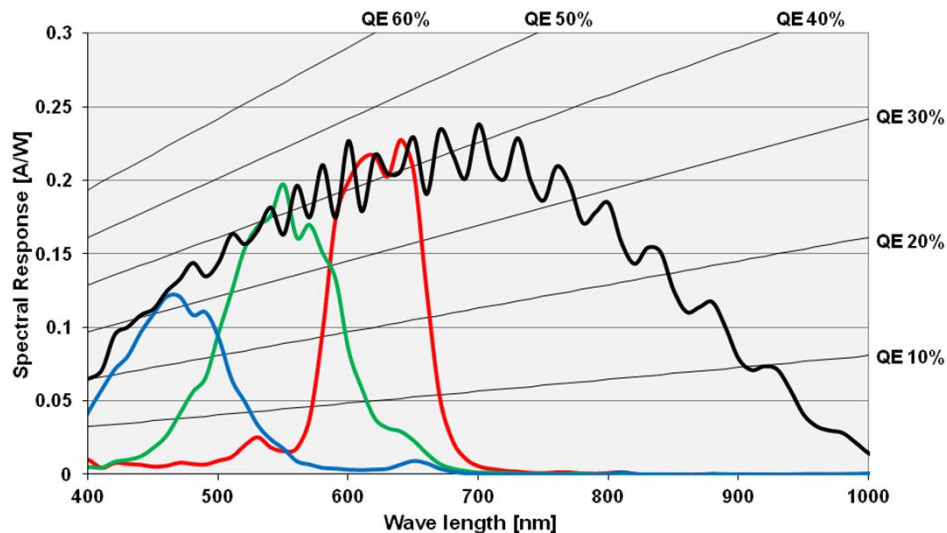

Light Sensitivity:

Expressions of light sensitivity in high-speed cameras can be confusing as a variety of differing measurement techniques are used. Photron publishes light sensitivity figures for its products using the ISO 12232 Ssat standard.

FASTCAM Mini AX	ISO 12232 Ssat
Monochrome models	ISO 40,000
Color models	ISO 16,000

ISO 12232 values published by Photron for both monochrome and color cameras are measured excluding infra-red sensitivity as defined by the ISO standard. Monochrome sensors used in FASTCAM Mini AX cameras are supplied without an IR filter, extending the camera spectral response beyond 900nm. When the sensitivity of the FASTCAM Mini AX camera is measured to tungsten light including near IR response an equivalent value greater than ISO 64,000 T is obtained.

Image Sensor:

The FASTCAM Mini AX system uses an advanced CMOS image sensor that is unique to Photron. The pixel pitch of the sensor is 20 microns giving a sensor size at full resolution of 20.48 x 20.48 mm (diagonal 28.96mm).

Lenses designed for both FX (35mm full frame) and also DX (APS-C digital SLR) formats are compatible with the FASTCAM Mini AX at full image resolution.

FASTCAM Mini AX

COMPACT HIGH-PERFORMANCE HIGH-SPEED CAMERA SYSTEM

Camera Performance Specifications:

Maximum Frame Rate (full sensor resolution)	4,000fps at 1024 x 1024 pixels
Maximum Frame Rate (reduced image resolution)	540,000fps at 128 x 16 pixels
Shutter Time	Global electronic shutter 1ms to 1 μ s independent of frame rate.
Inter-frame time (for PIV)	3.12 μ s (0.81 μ s @ >340kfps)
Ruggedized Mechanical Calibration Shutter	Standard feature
Dynamic Range (ADC)	12-bit
Memory Capacity Options	4GB: 2,726 frames at full resolution 8GB: 5,457 frames at full resolution 16GB: 10,918 frames at full resolution
Memory Partitions	Up to 64 memory segments
Region of Interest	Selectable in steps of 128 pixels (horizontal) x 16 pixels (vertical)
Trigger Inputs	Selectable +/- TTL 5V and switch closure
Trigger Delay	Programmable on selected input / output triggers: 100ns resolution
Input/ Output	Input: Trigger (TTL/Switch), Sync, Ready, Event, IRIG Output: Trigger, Sync, Ready, Rec, Exposure
Trigger Modes	Start, End, Centre, Manual, Random, Random Reset, Image trigger , Time Lapse
Time Code Input	IRIG-B
External Sync	+/- TTL 5Vp-p Variable Frequency Sync
Camera Control Interface	High Speed Dual Gigabit Ethernet
Image Data Display	Frame rate, Shutter speed, Trigger Mode, Date/Time, Status, Real time / IRIG Time, Frame count, Resolution
Saved Image Formats	BMP, TIFF, JPEG, PNG, RAW, RAWW, MRAW, AVI, WMV, FTIF, MOV. Images can be saved with or without image data and in 8-bit / 16-bit or bit depth of sensor where supported
Supported OS	Microsoft® Windows® Operating System including XP, Vista, 7, 8, 8.1 (32/64-bit)

High-Speed Gigabit Ethernet Interface:

FASTCAM Mini AX100 camera system is equipped with a high-speed Gigabit Ethernet interface to provide reliable network communication and fast download of image data.



High-G Mechanical Calibration Shutter:

The ruggedized mechanical shutter fitted as standard to the FASTCAM Mini AX camera allows sensor black balance calibration to be carried out remotely from the system control software.

Nikon G type Compatible Lens Fitting:

The FASTCAM Mini AX camera is equipped with an objective lens mount compatible with readily available Nikon G type lenses. Controls provided within the lens mount allow the control of lens aperture on lenses without external iris control.



Photron
High-Speed Imaging Solutions

Camera Operation Features:

Frame Synchronization	Accurate frame synchronization with other cameras and with external and unstable frequencies
Dual Slope Shutter (Extended Dynamic Range)	Selectable in 20 steps (0 to 95% in 5% increments) to prevent pixel over exposure without post processing
Memory Partitions	Up to 64 memory segments allow multiple events to be stored in camera memory before downloading, with automatic progression to the next available partition
Low Light Mode	Operation at minimum frame rate with separately adjustable shutter time to allow easy camera set-up and focus in ambient lighting
IRIG Phase Lock	Enables multiple cameras to be synchronised together with other instrumentation equipment to a master external time source
Internal Delay Generator	Allows programmable delays to be set on input and output triggers, 100ns resolution
Event Markers	Up to ten user entered event markers to define specific events within the recorded image sequence
Download While Recording	FASTCAM Mini AX supports Partition Recording Mode, allowing image data captured in one memory partition to be downloaded while at the same time recording into another partition
Automatic Download	The system can be set to automatically download image data to the control PC and, when download is complete re-arm in readiness for the next trigger with automatically incremented file names
Software Binning	Virtual pixel binning (2x2, 4x4 etc) allows increased light sensitivity with reduced image resolution without changing camera field of view

Dedicated I/O:

A dedicated BNC connection for a contact closure hardware trigger input is provided. In addition two programmable inputs and two programmable outputs provide direct connection for common tasks such as synchronization of multiple cameras and operation with Data Acquisition Hardware.



Multi-function Power Connector:

A multi-pin Lemo connection is fitted. This may be used as a standard power DC power input and is also compatible with Photron "J-box" hardware where a single connection provides not only power but also synchronization and trigger connections.



Photron J-Box

FASTCAM Mini AX

COMPACT HIGH-PERFORMANCE HIGH-SPEED CAMERA SYSTEM

Frame Rate / Image Resolution:

Frame Rate (FPS)	Image Resolution (Pixels)	
	Horizontal	Vertical
1,000 to 4,000 fps	1024	1024
5,400 fps	1024	816
8,500 fps	1024	512
5,400 fps	896	896
6,800 fps	768	768
13,600 fps	512	512
25,500 fps	512	256
45,900 fps	512	128
21,600 fps	384	384
30,000 fps	384	256
54,000 fps	384	128
37,500 fps	256	256
61,200 fps	256	128
102,000 fps	256	64
76,500 fps	128	128
127,500 fps	128	64
170,000 fps	128	32

Recordable Image Count

Image Resolution (pixels)	4GB Memory (frames)	8GB Memory (frames)	16GB Memory (frames)
1024 x 1024	2,726	5,457	10,918
1024 x 816	3,421	6,848	13,701
896 x 896	3,561	7,127	14,261
768 x 768	4,847	9,701	19,410
512 x 512	10,906	21,829	43,674
512 x 256	21,813	43,658	87,349
512 x 128	43,626	87,317	174,698
384 x 384	19,389	38,807	77,643
384 x 256	29,084	58,211	116,465
384 x 128	58,168	116,423	232,931
256 x 256	43,626	87,317	174,698
256 x 128	87,253	174,634	349,397
128 x 128	174,506	349,269	698,794
128 x 64	349,013	698,538	1,397,589
128 x 32	698,026	1,397,077	2,795,178

Variable Region of Interest mode:

Region of Interest (ROI) or sub-windowing allows a specific user-defined portion of the sensor to be used to capture images. By using just a selected portion of the image area, the frame rate at which images are recorded can be increased. FASTCAM Mini AX allows size of the ROI to be set in 128 pixel increments and vertical size to be set in 16 pixel increments.

Square Image Sensor Format:

Unlike broadcast and media applications where image formats such as 16:9 have now become standard, in scientific and industrial imaging applications an image sensor with a 1:1 image format is generally accepted to be advantageous. To capture the maximum useful image data in applications (including microscopy, detonics, combustion imaging and many others), a 1:1 sensor format provides greater flexibility than 'letterbox' image formats. The FASTCAM Mini AX image sensor allows the user to choose either square or rectangular image formats in order to obtain the maximum subject information.

External Frame Synchronisation:

The FASTCAM Mini AX camera can be fully synchronised with an external event to allow the timing of when each individual image is captured to be precisely referenced. The camera can be accurately synchronised to unstable frequencies allowing complex events such as combustion in rapidly accelerating or decelerating engine to be recorded and studied.

Record During Save Operation:

FASTCAM Mini AX recording memory can be divided into multiple active sections. The user can record an on-going event in one memory partition while at the same time downloading a previously recorded image sequence this can be used improve workflow and optimise camera operation.

Photron
High-Speed Imaging Solutions

FASTCAM Mini AX Operation Software Features:

Image Calibration	2D image calibration allows the measurement of distances and angle from the image. A calibration grid overlay can be superimposed on the image
Image Overlay	A stored reference image may be overlaid on the live image to allow accurate camera positioning to achieve the same view as a previous test
Import of Multiple Image Sequences	Multiple image sequences can be loaded and simultaneously replayed. Timing of image sequences can be adjusted to create a common time reference. Time based synchronisation allows images captured at different frame rates to be synchronised
High Dynamic Range mode	Making use of the full sensor dynamic range, HDR mode allows enhanced detail in both light and dark areas of an image to be displayed simultaneously
Motion Detector	In order to highlight subtle changes in an image Motion Detector allows a reference image to be subtracted from a recorded sequence. Details including propagation of shock waves and surface changes during impact can be visualised using this feature
Line Profile	A line profile representing grey levels along a line drawn across any region of the image is displayed. In live mode Line Profile can be used to ensure optimum image focus is achieved.
Histogram	A histogram displaying grey levels within a user defined image area is displayed. In live mode the Histogram can be used to ensure that optimum exposure levels are set for the scene being recorded.

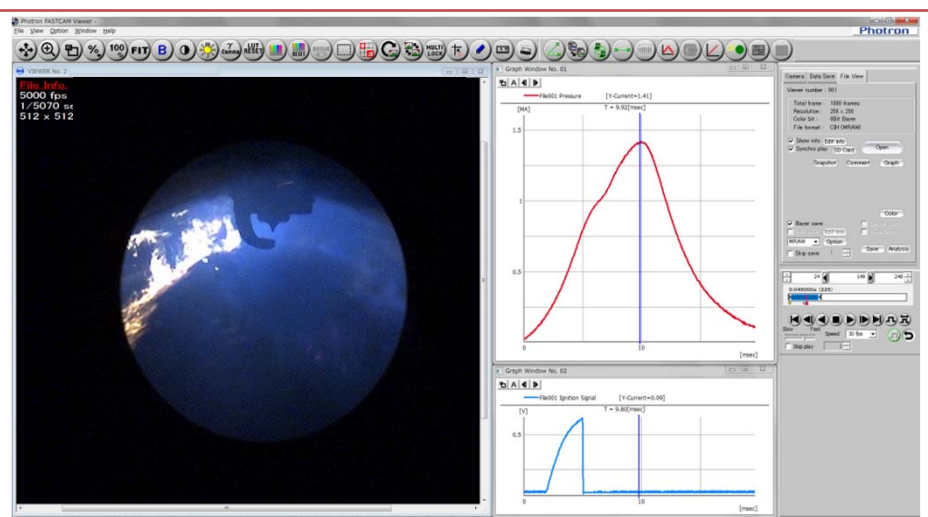

Photron FASTCAM Viewer image display together with synchronised data acquisition measurement

Photron FASTCAM Viewer:

Photron software provides a robust and reliable interface for control of the FASTCAM Mini AX camera. Clear on-screen controls provide intuitive operation of FASTCAM Mini AX camera functions. Advanced operation menus provide access to features for enhanced camera operation, image replay and export.

Included are tools allowing image calibration and simple measurement of angle and distances from image data.

National Instruments DAQ support:

A software plug-in is available for the FASTCAM Mini AX to support National Instruments USB-6361 / USB-6363 BNC DAQ modules. Optimized for superior accuracy and fast sampling rates, the system allows up to 32 channels (single ended) and 16 channels (differential) analogue data at sampling rates up to 2MS/s to be captured alongside high speed image data from the FASTCAM camera. This option allows a graphic display of DAQ data to be replayed in PFV software precisely synchronized and automatically linked with high speed images. 'Level Detection Triggering' allows the system to monitor data acquisition signals from an event and automatically trigger the high speed camera to start or stop recording images when levels exceed user pre-set reference values, allowing unpredictable and intermittent events to be reliably captured.

Motion Analysis:

PFV software allows image sequences to be exported directly to optional PFA Motion Analysis software. This entry level Motion Analysis software with an on screen 'step by step guide' function launches automatically from Photron FASTCAM Viewer software, and provides automated tracking of up to 5 points using a correlation tracking algorithm for the analysis of motion within an image sequence. Measurements of displacement, velocity and acceleration can be displayed and exported as comma separated values (csv files) to MS Excel etc.

FASTCAM Mini AX

COMPACT HIGH-PERFORMANCE HIGH-SPEED CAMERA SYSTEM

Mechanical and Environmental Specifications:

Mechanical

Lens Mount F mount (G-type lens compatible) and C mount provided. Optional lens mounts available include M42 adapter

Camera Mountings 2x ¼-20 UNC (base and top) | 4x M5(base)

External Dimensions (excluding protrusions)

Camera Body 120 (H) x 120 (W) x 98.9 (D) mm
4.72" (H) x 4.72" (W) x 3.89" (D)

Weight

Camera Body 1.6kg / 3.52 lbs

Environmental

Operating Temperature 0 ~ 40 deg. C | 32 ~ 104 deg.F

Storage Temperature -20 ~ 60 deg C.

Humidity 85% or less (non condensing)

Cooling Internal fan cooling
(Fan-off mode supported)

Operational Shock 100G, 10ms, 6-axis

Power

AC Power (with supplied adapter) 100 ~ 240V, 50 ~ 60 Hz

DC Power 22 ~ 32V, 40VA

Coupling to other lens systems:

A combination of small physical size, low weight and high light sensitivity allow the FASTCAM Mini AX to be coupled to a range of optical systems such as scientific and long distance microscopes, rigid endoscopes or borescopes, and image intensifiers for applications ranging from imaging flows in microfluidic devices to combustion diagnostics.



FASTCAM Mini AX specifications match PIV and DIC requirements:

For optical measurement techniques such as Particle Image Velocimetry (PIV) and Digital Image Correlation (DIC), the FASTCAM Mini AX has some key performance specifications desired for these measurement systems:

High Light Sensitivity: For PIV, a sensitive image sensor allows use of smaller tracer particles and/or lower laser power. For μ PIV, the ability to detect low light from fluorescent particles is essential. For DIC, a higher lens aperture number achievable with a more sensitive sensor yields better depth of field for those objects having a large out of plane displacement.

Small Physical Size: The small physical size and weight of the Mini camera range allows the use of more conventional opto-mechanical hardware for rigid and stable mounting of multiple cameras.

All dimensions are given in millimeters

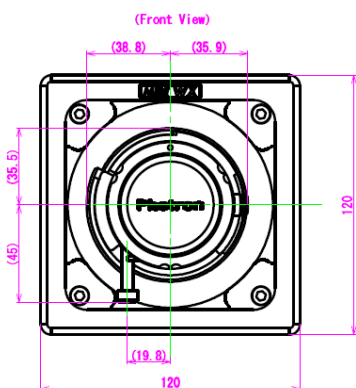
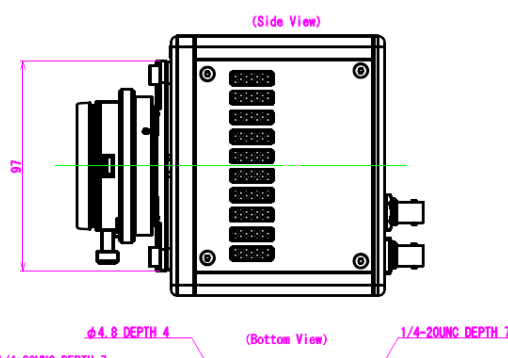
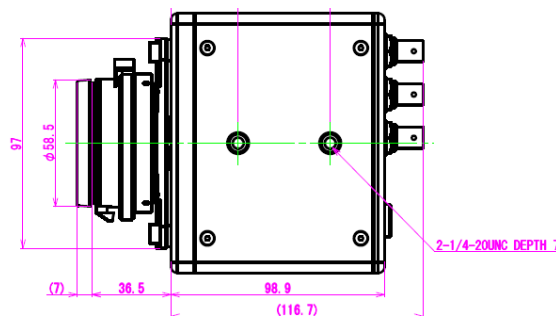

Photron
High-Speed Imaging Solutions

FASTCAM Mini AX

COMPACT HIGH-PERFORMANCE HIGH-SPEED CAMERA SYSTEM

Credibility and reputation through technological achievement:

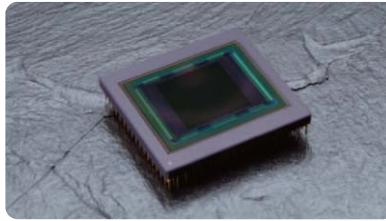

Developments in advanced imaging technologies pioneered by Photron over the past 20 years are now being utilized in high-speed camera systems designed for a range of scientific and industrial development applications. Photron has invested in the development of unique

advanced CMOS image sensors, the core technology of high speed photography. Innovations in this area have led to a rapid increase in camera performance allowing high-speed imaging to be applied to important new subject areas.

The highest quality design, manufacturing and support:

As an ISO9001:2008 certified manufacturer, Photron manufactures its full range of imaging systems at its own facility located in Yonezawa City Yamagata Prefecture, Japan.

International technical support centres located in the USA, Europe and China, staffed by factory trained engineers and holding a full range of support equipment, ensure fast and professional local support for Photron camera users around the world.



FASTCAM, the leading name worldwide in high speed imaging:



Used in internationally renowned research facilities more than 30 countries worldwide, Photron FASTCAM high speed cameras are trusted to provide high quality results in the most challenging applications and environments. Photron continues to utilise the latest technological innovations to

further advance product performance in order to meet the most demanding requirements from users around the world.

Specialist high-speed imaging applications knowledge:

For more than 30 years, Photron has focussed on the design and application of high-speed imaging products. Photron's specialist applications engineers have a wealth of knowledge and experience in demanding imaging requirements and are able to advise both new and experienced users on High-speed imaging solutions and imaging techniques to achieve the optimum results.



Contacts:

PHOTRON LIMITED

Kanda Jinbo-cho 1-105
Chiyoda-Ku, Tokyo 101-0051
Japan

Tel: +81 (0) 3 3518 6271

Fax: +81 (0) 3 3518 6279

Email: image@photron.co.jp

www.photron.co.jp

PHOTRON (SHANGHAI) LIMITED

Room 20C, ZhaoFeng World Trade Building
NO.369, JiangSu Road, ChangNing District
Shanghai 200050
China

Tel: +86 (0)21-5268-3700

Fax: +86 (0)21-5268-3702

Email: info@photron.cn.com

www.photron.cn.com

PHOTRON USA, INC.

9520 Padgett Street, Suite 110
San Diego, CA 92126-4446
USA

Tel: +1 858 684 3555 or +1 800 585 2129

Fax: +1 858 684 3558

Email: image@photron.com

www.photron.com

PHOTRON (EUROPE) LIMITED

The Barn, Bottom Road
West Wycombe
Buckinghamshire, HP14 4BS
United Kingdom

Tel: +44 (0) 1494 481011

Fax: +44 (0) 1494 487011

Email: image@photron.com

www.photron.com

Photron
High-Speed Imaging Solutions